

12.5 Ball Chain Type, SME Series

A. Construction

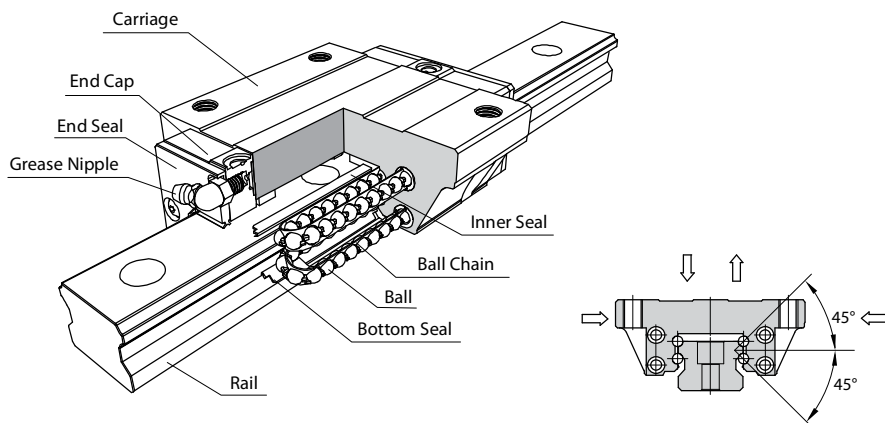

B. Characteristics

The ball chain type linear guideway, SME series, equip with the patent of ball chain design can make the movement smooth and stability, especially suit for the requests of high speed, high accuracy.

The Optimization Design of Four Directional Load

Through the structure stress analysis, SME series have four trains of balls are designed to a circular contact angle of 45° and the section design for high rigidity. Except for bearing heavier loads in radial, reversed radial and lateral directions, a sufficient preload can be achieved to increase rigidity, and this makes it suitable for any kind of installation.

Self Alignment Capability

The self adjustment is performed spontaneously as the design of face-face (DF) circular arc groove. Therefore, the installation error could be compensated even under a preload, and which results in precise and smooth linear motion.

Ball Chain Design, Smooth Movement

The concise and smooth design of circulating system with strengthened synthetic resin accessories and cooperating with the ball chain, these can avoid interference between balls and make the balls more stability during passing in and out the load district. Besides, the ball chain can keep the ball move in a line and improve the movement most smooth substantially.

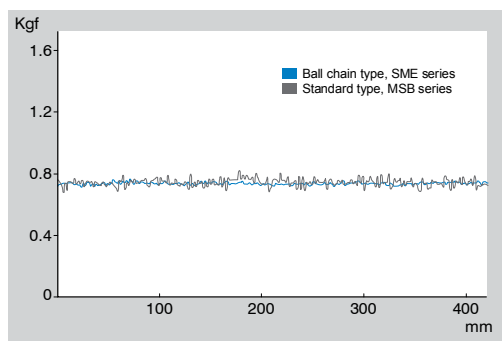

Rolling resistance test

Low Noise, Good Lubricant Effect

The ball chain design avoids interference between balls, lowers the operating noise, and can keep the lubricant between the balls and ball chain effectively. Moreover, improve the movement smooth and service life of the whole, can meet high accuracy, high reliability and smooth and stability.

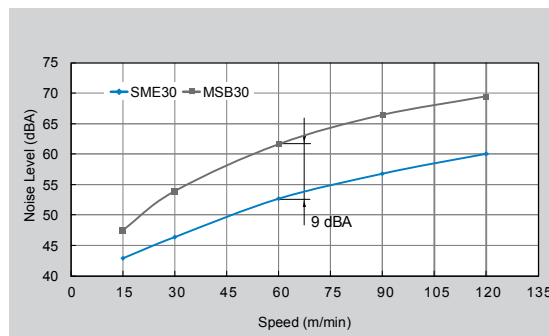

Noise level comparison test

C. Carriage Type

Heavy Load

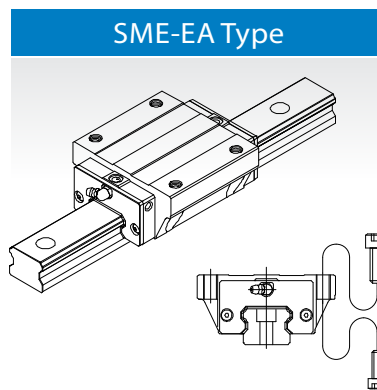

This type offers the installation either from top or bottom side of carriage.

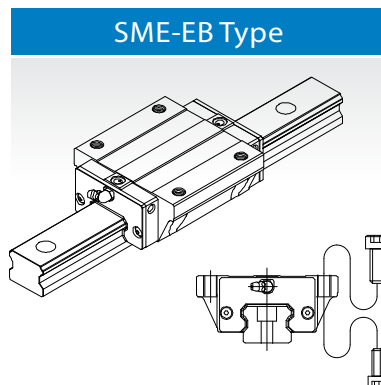

All dimensions are same as SME-EA except the mounting hole dimensions of carriage are different and the height is lower, which do not change the basic loading rating.

SME-SA Type

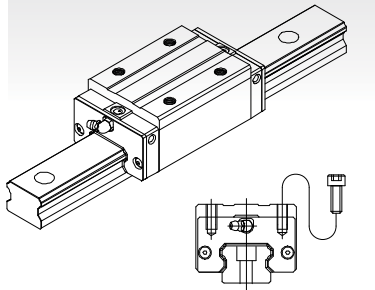

Square type with smaller width and can be installed from top side of carriage.

SME-SB / SME-SV Type

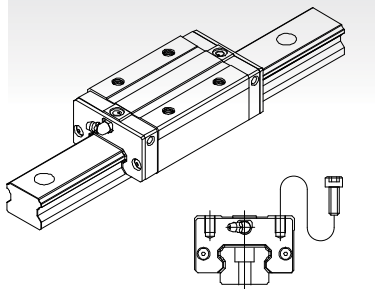

All dimensions are same as SME-SA except the mounting hole dimensions of carriage are different and the height is lower, which do not change the basic loading rating.

Ultra Heavy Load

SME-LEA Type

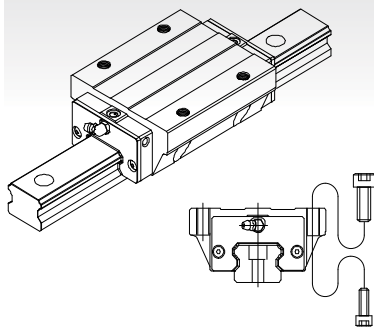

All dimensions are same as SME-EA except the length is longer, which makes it more rigid.

SME-LEB Type

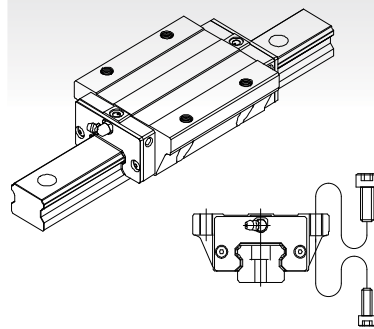

All dimensions are same as SME-EB except the length is longer, which makes it more rigid.

SME-LSA Type

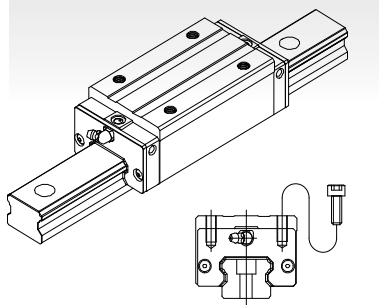

All dimensions are same as SME-SA except the length is longer, which makes it more rigid.

SME-LSB / SME-LSV Type

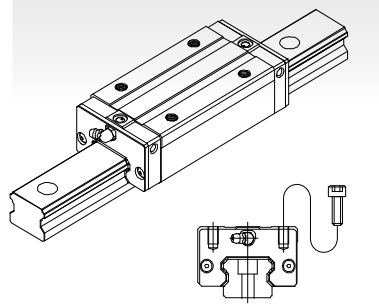

All dimensions are same as SME-SB and SME-SV except the length is longer, which makes it more rigid.

D. Rail Type

Counter bore(R type)

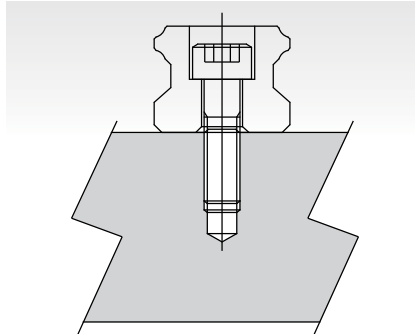

Tapped-Hole(T type)

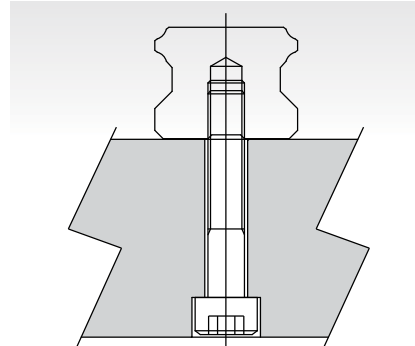

E. Description of Specification

(1) Non-interchangeable Type

	SME	25	EA	2	SS	F0
Series : SME						
Size : 15, 20, 25, 30, 35, 45						
Carriage type : (1) Heavy load						
EA : Flange type, mounting either from top or bottom						
EB : Compact flange type, mounting either from top or bottom						
SA : Square type						
SB/SV : Compact square type						
(2) Ultra heavy load						
LEA : Flange type, mounting either from top or bottom						
LEB : Compact flange type, mounting either from top or bottom						
LSA : Square type						
LSB/LSV : Compact square type						
Number of carriages per rail : 1, 2, 3 ...						
Dust protection option of carriage : No symbol, UU, SS, ZZ, DD, KK (refer to chapter 15.1 Dust Proof)						
Preload : FC (Light Preload), F0 (Medium preload), F1 (Heavy preload)						
Code of special carriage : No symbol, A, B, C, D ...						
Rail type : R (Counter-bore type), T (Tapped hole type)						
Rail length (mm)						
Rail hole pitch from start side (E1, see Fig.12.5)						
Rail hole pitch to the end side (E2, see Fig.12.5)						
Accuracy grade : N, H, P, SP, UP						
Code of special rail : No symbol, A, B ...						
Dust protection option of rail : No symbol, /CC, /MC, /MD ... (refer to chapter 15.1 Code of contamination fro Rail)						
Number of rails per axis : No symbol, II, III, IV ...						

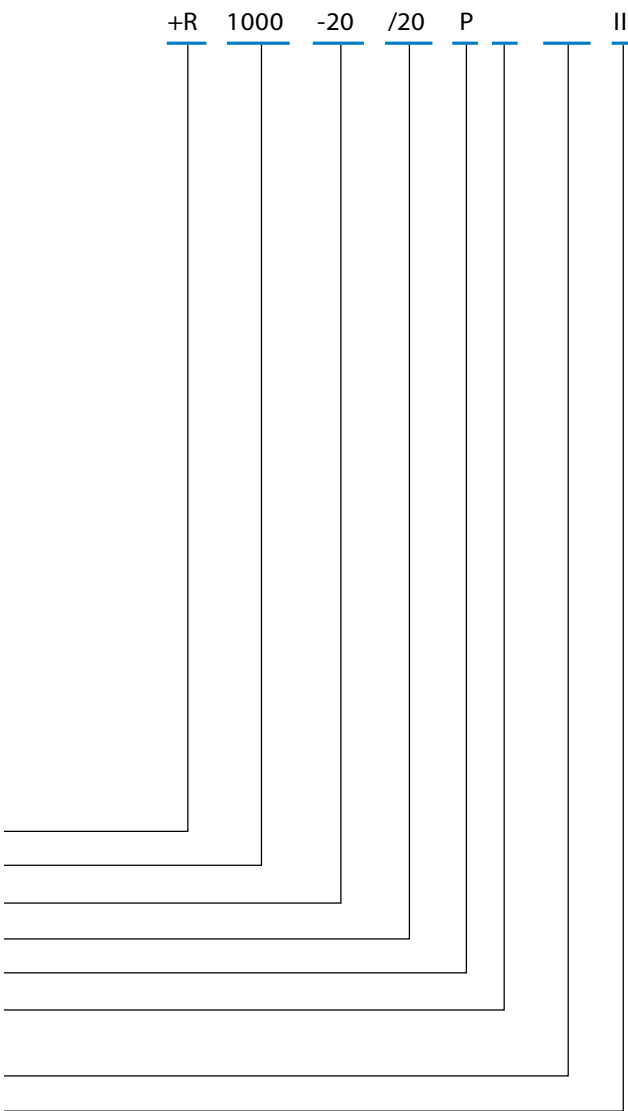

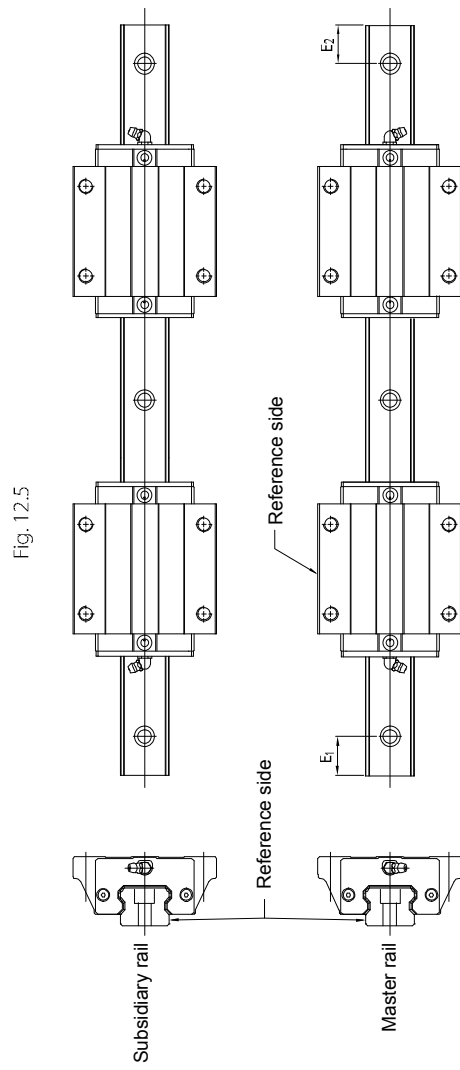
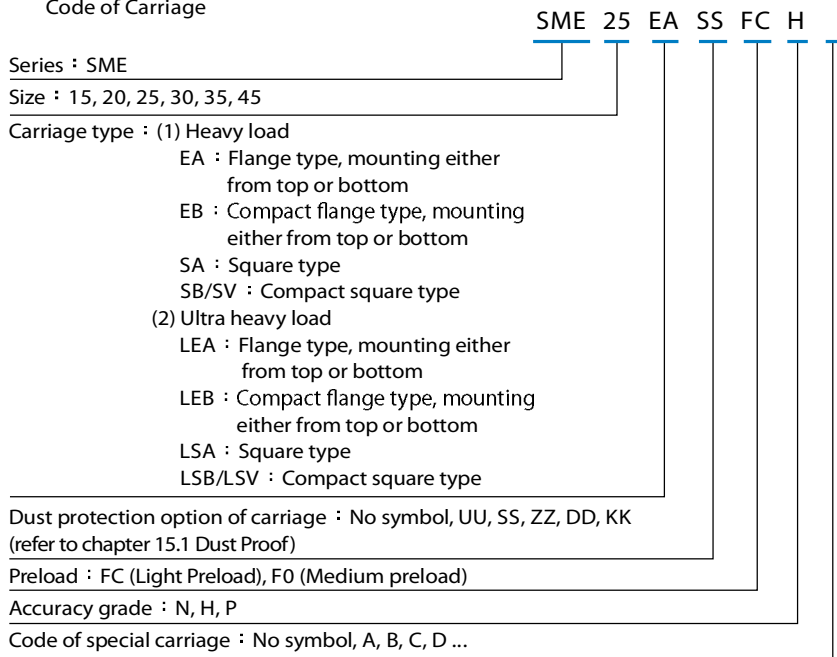

Fig. 12.5

(2) Interchangeable Type

Code of Carriage



Code of Rail

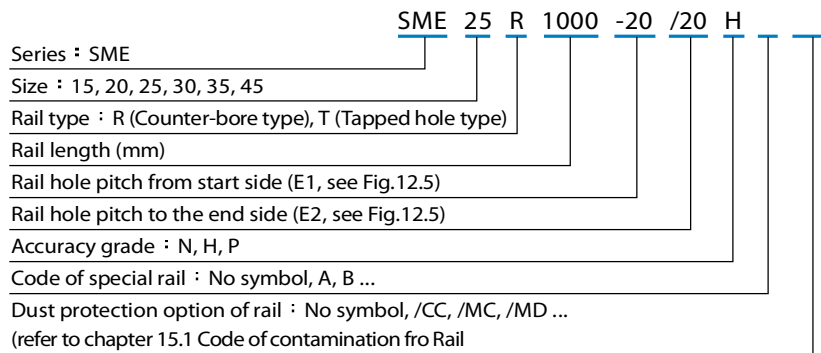

F. Accuracy Grade

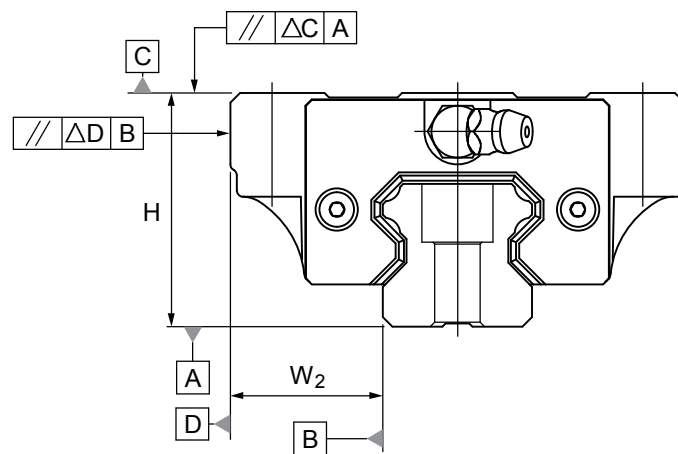

Table 1 Running Parallelism

Rail length (mm)		Running Parallelism Values (μm)				
Above	Or less	N	H	P	SP	UP
0	315	9	6	3	2	1.5
315	400	11	8	4	2	1.5
400	500	13	9	5	2	1.5
500	630	16	11	6	2.5	1.5
630	800	18	12	7	3	2
800	1000	20	14	8	4	2
1000	1250	22	16	10	5	2.5
1250	1600	25	18	11	6	3
1600	2000	28	20	13	7	3.5
2000	2500	30	22	15	8	4
2500	3000	32	24	16	9	4.5
3000	3500	33	25	17	11	5
3500	4000	34	26	18	12	6

A Non-Interchangeable Type

Model No.	Item	Accuracy Grade				
		Normal N	High H	Precision P	Super Precision SP	Ultra Precision UP
15 20	Tolerance for height H	±0.1	±0.03	0 -0.03	0 -0.015	0 -0.008
	Height difference ΔH	0.02	0.01	0.006	0.004	0.003
	Tolerance for distance W_2	±0.1	±0.03	0 -0.03	0 -0.015	0 -0.008
	Difference in distance $W_2(\Delta W_2)$	0.02	0.01	0.006	0.004	0.003
	Running parallelism of surface C with surface A	ΔC (see the table 1)				
	Running parallelism of surface D with surface B	ΔD (see the table 1)				
25 30 35	Tolerance for height H	±0.1	±0.04	0 -0.04	0 -0.02	0 -0.01
	Height difference ΔH	0.02	0.015	0.007	0.005	0.003
	Tolerance for distance W_2	±0.1	±0.04	0 -0.04	0 -0.02	0 -0.01
	Difference in distance $W_2(\Delta W_2)$	0.03	0.015	0.007	0.005	0.003
	Running parallelism of surface C with surface A	ΔC (see the table 1)				
	Running parallelism of surface D with surface B	ΔD (see the table 1)				
45	Tolerance for height H	±0.1	±0.05	0 -0.05	0 -0.03	0 -0.02
	Height difference ΔH	0.03	0.015	0.007	0.005	0.003
	Tolerance for distance W_2	±0.1	±0.05	0 -0.05	0 -0.03	0 -0.02
	Difference in distance $W_2(\Delta W_2)$	0.03	0.02	0.01	0.007	0.005
	Running parallelism of surface C with surface A	ΔC (see the table 1)				
	Running parallelism of surface D with surface B	ΔD (see the table 1)				

B Interchangeable Type

Model No.	Item	Accuracy Grade		
		Normal N	High H	Precision P
15 20	Tolerance for height H	±0.1	±0.03	0 -0.03
	Height difference ΔH	0.02	0.01	0.006
	Tolerance for distance W_2	±0.1	±0.03	0 -0.03
	Difference in distance $W_2(\Delta W_2)$	0.02	0.01	0.006
	Running parallelism of surface C with surface A	ΔC (see the table 1)		
	Running parallelism of surface D with surface B	ΔD (see the table 1)		
25 30 35	Tolerance for height H	±0.1	±0.04	0 -0.04
	Height difference ΔH	0.02	0.015	0.007
	Tolerance for distance W_2	±0.1	±0.04	0 -0.04
	Difference in distance $W_2(\Delta W_2)$	0.03	0.015	0.007
	Running parallelism of surface C with surface A	ΔC (see the table 1)		
	Running parallelism of surface D with surface B	ΔD (see the table 1)		
45	Tolerance for height H	±0.1	±0.05	0 -0.05
	Height difference ΔH	0.03	0.015	0.007
	Tolerance for distance W_2	±0.1	±0.05	0 -0.05
	Difference in distance $W_2(\Delta W_2)$	0.03	0.02	0.01
	Running parallelism of surface C with surface A	ΔC (see the table 1)		
	Running parallelism of surface D with surface B	ΔD (see the table 1)		

G. Preload Grade

Series	Preload grade		
	Light preload (FC)	Medium preload (F0)	Heavy preload (F1)
SME15	0.01~0.03C	0.04~0.06C	-
SME20			
SME25			
SME30			0.07~0.09C
SME35			
SME45			
SME15L	0.01~0.03C	0.04~0.06C	0.07~0.09C
SME20L			
SME25L			
SME30L			
SME35L			
SME45L			

Note: C is basic dynamic load rating in above table. Refer to the specification of products, please.

H. The Shoulder Height and Corner Radius for Installation

SME series

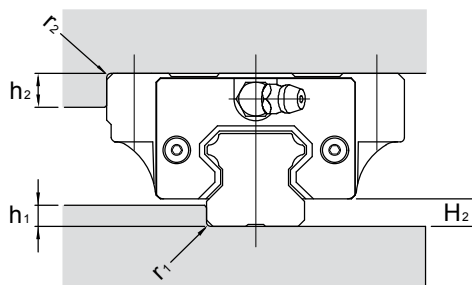

Unit: mm

Model No.	r ₁ (max.)	r ₂ (max.)	h ₁	h ₂	H ₂
15	0.5	0.5	2.5	5	3.5
20	0.5	0.5	3.5	5	4.7
25	1	1	5	6	5.8
30	1	1	5	7	7.5
35	1	1	6	8	8
45	1	1	8	8	10

I. Dimensional Tolerance of Mounting Surface

SME with the self alignment capability, the minor dimensional error in mounting surface could be compensated and achieves smooth linear motion. The tolerances of parallelism between two axes are shown as below.

The parallel deviation between two axes (e_1)

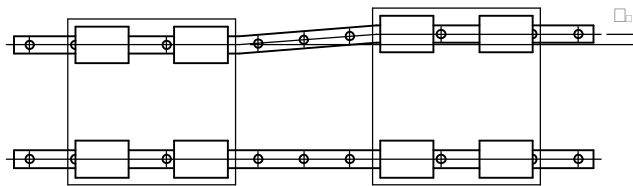

Unit: μm

Model No.	Preload Grade		
	FC	F0	F1
15	25	18	-
20	25	20	18
25	30	22	20
30	40	30	27
35	50	35	30
45	60	40	35

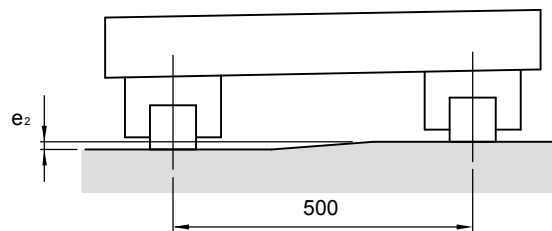
Level difference between two axes (e_2)Unit: μm

Model No.	Preload Grade		
	FC	F0	F1
15	130	85	-
20	130	85	50
25	130	85	70
30	170	110	90
35	210	150	120
45	250	170	140

Note: The permissible values in table are applicable when the span is 500mm wide.

J. Rail Maximum Length and Standrad

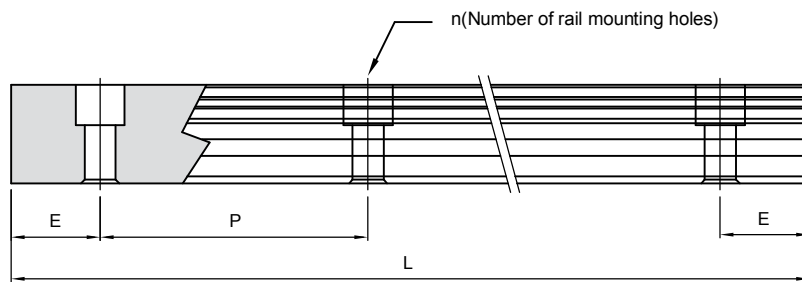

$$L = (n-1) \times P + 2 \times E$$

L: Total Length of rail (mm)

n: Nuber of mounting holes

P: Distance between any two holes (mm)

E: Distance from the center of the last hole to the edge (mm)

Unit: mm

Model No.	Standard Pitch (P)	Standard (E _{std.})	Minimum (E _{min.})	Max (L ₀ max.)
SME 15	60	20	5	4000
SME 20	60	20	6	4000
SME 25	60	20	7	4000
SME 30	80	20	8	4000
SME 35	80	20	8	4000
SME 45	105	22.5	11	4000

K. Tapped-hole Rail Dimensions

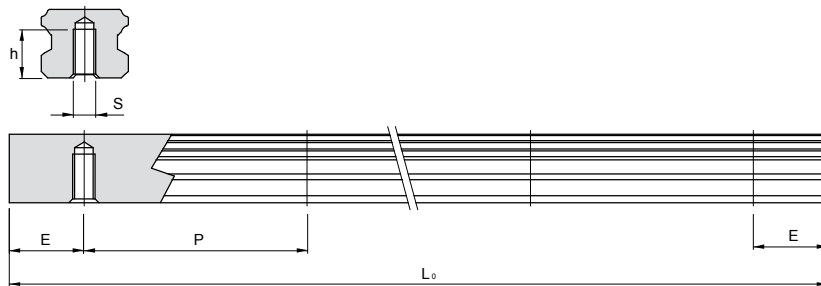

Rail Model	S	h(mm)
SME 15 T	M5	8
SME 20 T	M6	10
SME 25 T	M6	12
SME 30 T	M8	15
SME 35 T	M8	17
SME 45 T	M12	24

Dimensions of SME-EA / SME-LEA

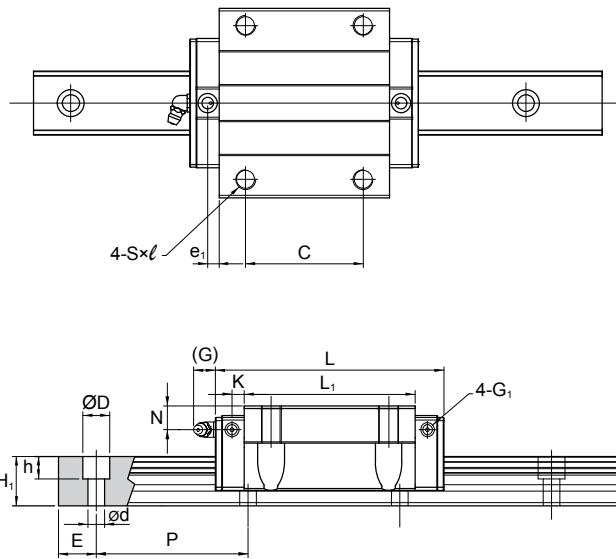

Unit: mm

Model No.	External dimension					Carriage dimension											Grease Nipple
	Height H	Width W	Length L	W ₂	H ₂	B	C	S × l	L ₁	T	T ₁	N	G	K	e ₁	G ₁	
SME 15 EA SME 15 LEA	24	47	64.4 79.4	16	3.5	38	30	M5×8	48 63	5.5	8	5	5.5	2.7	-	M4	G-M4
SME 20 EA SME 20 LEA	30	63	78.5 97.5	21.5	4.7	53	40	M6×10	58.3 77.3	7	10	8	12	3.7	-	M4	G-M6
SME 25 EA SME 25 LEA	36	70	92 109	23.5	5.8	57	45	M8×13	71 88	7	13	10	12	4.7	-	M4	G-M6
SME 30 EA SME 30 LEA	42	90	107.6 132.6	31	7.5	72	52	M10×15	80 105	12	15	8	12	4.5	5.4	M6	G-M6
SME 35 EA SME 35 LEA	48	100	120.6 150.6	33	8	82	62	M10×15	90 120	12	15	8	12	5.4	6	M6	G-M6
SME 45 EA SME 45 LEA	60	120	140 174.5	37.5	10	100	80	M12×18	106 140.5	12	18	10	13.5	8.5	6.1	M6	G-PT 1/8

Note: The basic dynamic load rating C of ball type is based on the 50 km for nominal life. The conversion between C for 50 km and C₁₀₀ for 100 km is C=1.26 × C₁₀₀.

Note*: Single: Single carriage/ Double: Double carriages closely contacting with each other.

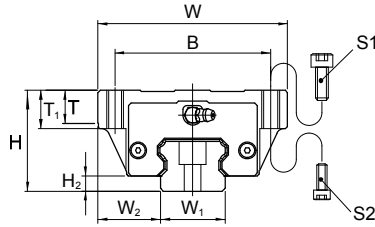
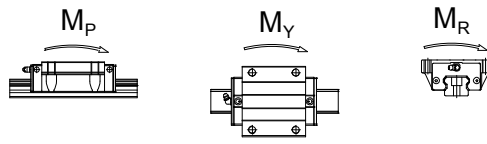

Model No.	Bolt Size	
	S ₁	S ₂
SME 15	M5	M4
SME 20	M6	M5
SME 25	M8	M6
SME 30	M10	M8
SME 35	M10	M8
SME 45	M12	M10

Unit: mm

Model No.	Rail dimension					Basic load rating		Static moment rating				Weight		
	Width W ₁	Height H ₁	Pitch P	E std.	D × h × d	Dynamic C kN	Static C ₀ kN	M _x kN-m		M _y kN-m		M _r kN-m	Carriage kg	Rail kg/m
								Single*	Double*	Single*	Double*			
SME 15 EA SME 15 LEA	15	13	60	20	7.5×5.8×4.5	12.5 15.4	20.2 27.5	0.14 0.25	0.69 1.15	0.14 0.25	0.69 1.15	0.16 0.21	0.22 0.29	1.4
SME 20 EA SME 20 LEA	20	15.5	60	20	9.5×8.5×6	20.4 25.3	32.1 43.6	0.27 0.49	1.34 2.24	0.27 0.49	1.34 2.24	0.33 0.44	0.42 0.62	2.3
SME 25 EA SME 25 LEA	23	18	60	20	11×9×7	28.3 33.0	44.3 56.1	0.45 0.71	2.14 3.20	0.45 0.71	2.14 3.20	0.52 0.66	0.67 0.89	3.2
SME 30 EA SME 30 LEA	28	23	80	20	14×12×9	39.4 47.0	59.5 76.5	0.68 1.11	3.37 5.32	0.68 1.11	3.37 5.32	0.83 1.07	1.18 1.54	4.5
SME 35 EA SME 35 LEA	34	26	80	20	14×12×9	54.7 67.6	81.0 109.9	1.07 1.92	5.25 8.75	1.07 1.92	5.25 8.75	1.41 1.91	1.74 2.28	6.2
SME 45 EA SME 45 LEA	45	32	105	22.5	20×17×14	72.7 90.0	105.8 143.6	1.61 2.88	7.82 13.08	1.61 2.88	7.82 13.08	2.41 3.27	3.22 4.21	10.5

Dimensions of SME-EB / SME-LEB

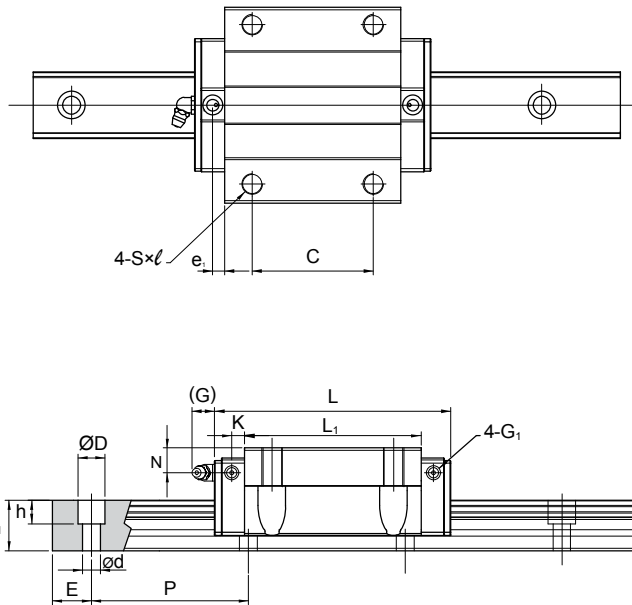

Unit: mm

Model No.	External dimension					Carriage dimension												
	Height H	Width W	Length L	W_2	H_2	B	C	$S \times l$	L_1	T	T_1	N	G	K	e_1	G_1	Grease Nipple	
SME 15 EB SME 15 LEB	24	52	64.4 79.4	18.5	3.5	41	26 36	M5×8	48 63	5.5	8	5	5.5	2.7	-	M4	G-M4	
SME 20 EB SME 20 LEB	28	59	78.5 97.5	19.5	4.7	49	32 45	M6×8	58.3 77.3	7.0	8	6.0	12	3.7	-	M4	G-M6	
SME 25 EB SME 25 LEB	33	73	92 109	25	5.8	60	35 50	M8×10	71 88	7.0	10	7.0	12	4.7	-	M4	G-M6	

Note: The basic dynamic load rating C of ball type is based on the 50 km for nominal life. The conversion between C for 50 km and C_{100} for 100 km is $C=1.26 \times C_{100}$.

Note*: Single: Single carriage/ Double: Double carriages closely contacting with each other.

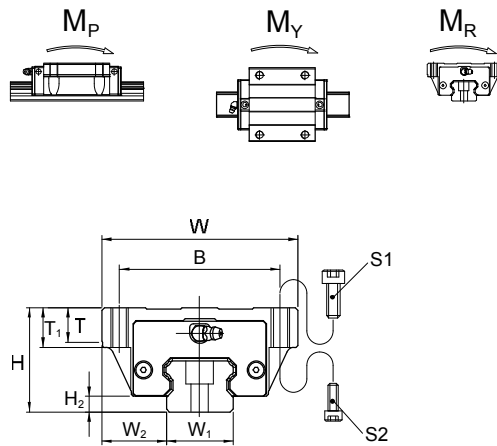

Model No.	Bolt Size	
	S ₁	S ₂
SME 15	M5	M4
SME 20	M6	M5
SME 25	M8	M6

Unit: mm

Model No.	Rail dimension					Basic load rating		Static moment rating				Weight		
	Width W ₁	Height H ₁	Pitch P	E std.	D × h × d	Dynamic C kN	Static C ₀ kN	M _p kN-m		M _y kN-m		M _r kN-m	Carriage kg	Rail kg/m
								Single*	Double*	Single*	Double*			
SME 15 EB SME 15 LEB	15	13	60	20	7.5×5.8×4.5	12.5 15.4	20.2 27.5	0.14 0.25	0.69 1.15	0.14 0.25	0.69 1.15	0.16 0.21	0.21 0.27	1.4
SME 20 EB SME 20 LEB	20	15.5	60	20	9.5×8.5×6	20.4 25.3	32.1 43.6	0.27 0.49	1.34 2.24	0.27 0.49	1.34 2.24	0.33 0.44	0.39 0.55	2.3
SME 25 EB SME 25 LEB	23	18	60	20	11×9×7	28.3 33.0	44.3 56.1	0.45 0.71	2.14 3.20	0.45 0.71	2.14 3.20	0.52 0.66	0.42 0.65	3.2

Dimensions of SME-SA / SME-LSA

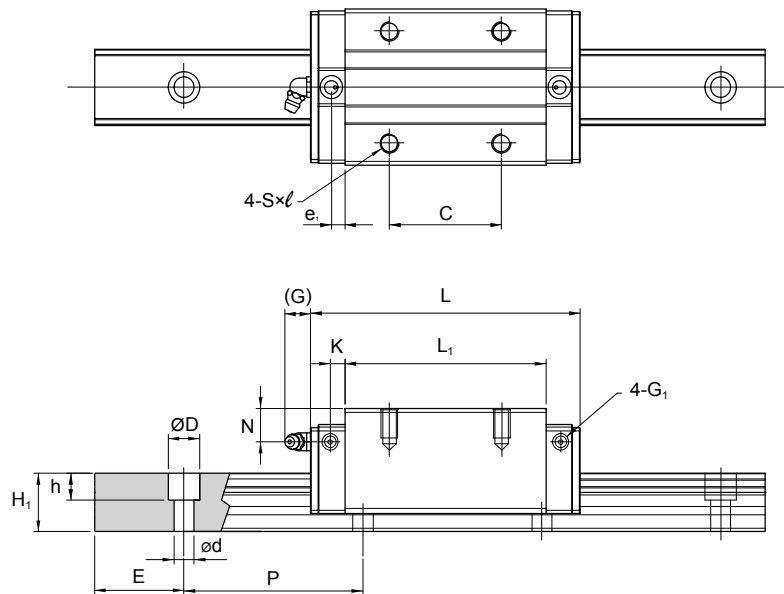

Unit: mm

Model No.	External dimension					Carriage dimension											Grease Nipple
	Height H	Width W	Length L	W ₂	H ₂	B	C	S × l	L ₁	T	N	G	K	e ₁	G ₁		
SME 15 SA SME 15 LSA	28	34	64.4 79.4	9.5	3.5	26	26	M4×7.5	48 63	6	9	5.5	2.7	-	M4	G-M4	
SME 20 SA SME 20 LSA	30	44	78.5 97.5	12	4.7	32	36 50	M5×7	58.3 77.3	6	8	12	3.7	-	M4	G-M6	
SME 25 SA SME 25 LSA	40	48	92 109	12.5	5.8	35	35 50	M6×12	71 88	8	14	12	4.7	-	M4	G-M6	
SME 30 SA SME 30 LSA	45	60	107.6 132.6	16	7.5	40	40 60	M8×12	80 105	8	11	12	4.5	5.4	M6	G-M6	
SME 35 SA SME 35 LSA	55	70	120.6 150.6	18	8	50	50 72	M8×14	90 120	11	15	12	5.4	6	M6	G-M6	
SME 45 SA SME 45 LSA	70	86	140 174.5	20.5	10	60	60 80	M10×20	106 140.5	16	20	13.5	8.5	6.1	M6	G-PT 1/8	

Note: The basic dynamic load rating C of ball type is based on the 50 km for nominal life. The conversion between C for 50 km and C₁₀₀ for 100 km is C=1.26 × C₁₀₀.

Note*: Single: Single carriage/ Double: Double carriages closely contacting with each other.

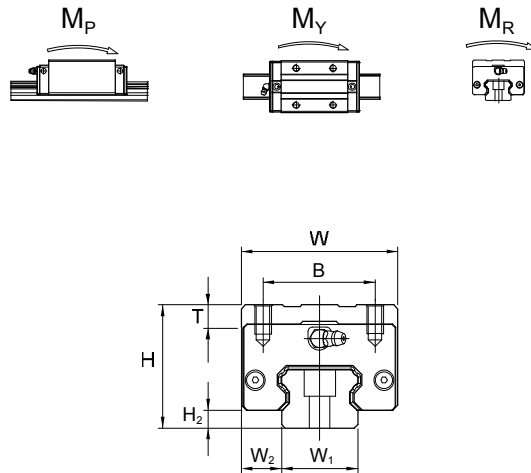

Unit: mm

Model No.	Rail dimension					Basic load rating		Static moment rating				Weight		
	Width W ₁	Height H ₁	Pitch P	E std.	D × h × d	Dynamic C	Static C ₀	M _p kN-m		M _y kN-m		M _r kN-m	Carriage kg	Rail kg/m
								Single*	Double*	Single*	Double*			
SME 15 SA SME 15 LSA	15	13	60	20	7.5×5.8×4.5	12.5 15.4	20.2 27.5	0.14 0.25	0.69 1.15	0.14 0.25	0.69 1.15	0.16 0.21	0.22 0.25	1.4
SME 20 SA SME 20 LSA	20	15.5	60	20	9.5×8.5×6	20.4 25.3	32.1 43.6	0.27 0.49	1.34 2.24	0.27 0.49	1.34 2.24	0.33 0.44	0.30 0.39	2.3
SME 25 SA SME 25 LSA	23	18	60	20	11×9×7	28.3 33.0	44.3 56.1	0.45 0.71	2.14 3.20	0.45 0.71	2.14 3.20	0.52 0.66	0.56 0.73	3.2
SME 30 SA SME 30 LSA	28	23	80	20	14×12×9	39.4 47.0	59.5 76.5	0.68 1.11	3.37 5.32	0.68 1.11	3.37 5.32	0.83 1.07	0.93 1.21	4.5
SME 35 SA SME 35 LSA	34	26	80	20	14×12×9	54.7 67.6	81.0 109.9	1.07 1.92	5.25 8.75	1.07 1.92	5.25 8.75	1.41 1.91	1.57 2.05	6.2
SME 45 SA SME 45 LSA	45	32	105	22.5	20×17×14	72.7 90.0	105.8 143.6	1.61 2.88	7.82 13.08	1.61 2.88	7.82 13.08	2.41 3.27	3.06 4.00	10.5

Dimensions of SME-SB / SME-LSB

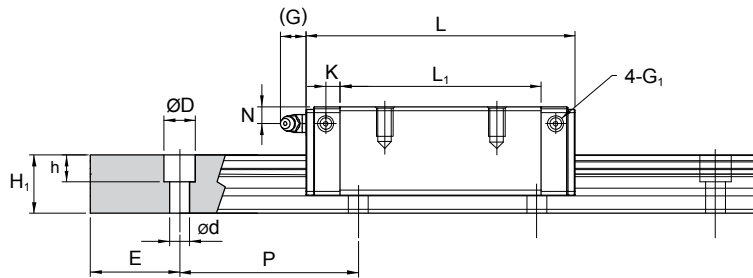
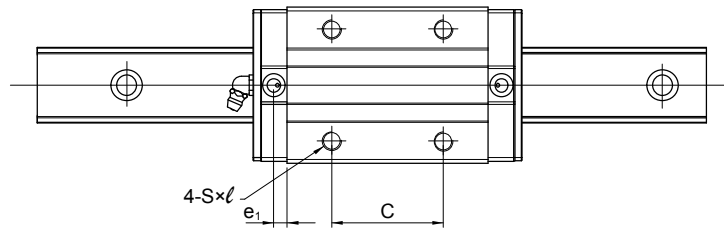

Unit: mm

Model No.	External dimension						Carriage dimension											Grease Nipple
	Height H	Width W	Length L	W ₂	H ₂	B	C	S × l	L ₁	T	N	G	K	e ₁	G ₁			
SME 15 SB SME 15 LSB	24	34	64.4 79.4	9.5	3.5	26	26 34	M4×5	48 63	6	5	5.5	2.7	-	M4	G-M4		
SME 20 SB SME 20 LSB	28	42	78.5 97.5	11	4.7	32	32 45	M5×5.5	58.3 77.3	6	6	12	3.7	-	M4	G-M6		
SME 25 SB SME 25 LSB	33	48	92 109	12.5	5.8	35	35 50	M6×7	71 88	8	7	12	4.7	-	M4	G-M6		
SME 25 SV SME 25 LSV	36	48	92 109	12.5	5.8	35	35 50	M6×9	71 88	8	10	12	4.7	-	M4	G-M6		
SME 30 SB SME 30 LSB	42	60	107.6 132.6	16	7.5	40	40 60	M8×10	80 105	8	8	12	4.5	5.4	M6	G-M6		
SME 35 SB SME 35 LSB	48	70	120.6 150.6	18	8	50	50 72	M8×11	90 120	11	8	12	5.4	6	M6	G-M6		
SME 45 SB SME 45 LSB	60	86	140 174.5	20.5	10	60	60 80	M10×16	106 140.5	16	10	13.5	8.5	6.1	M6	G-PT 1/8		

Note: The basic dynamic load rating C of ball type is based on the 50 km for nominal life. The conversion between C for 50 km and C₁₀₀ for 100 km is C=1.26 × C₁₀₀.

Note*: Single: Single carriage/ Double: Double carriages closely contacting with each other.

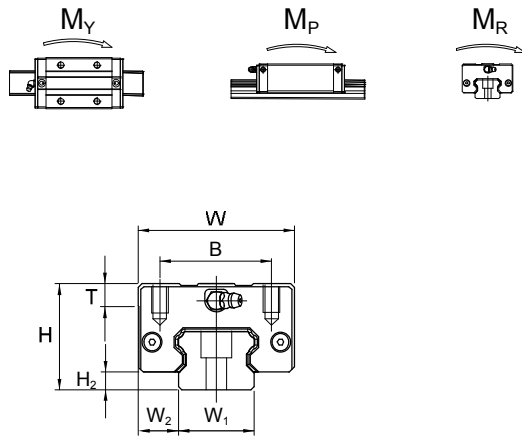

Unit: mm

Model No.	Rail dimension					Basic load rating		Static moment rating				Weight		
	Width W ₁	Height H ₁	Pitch P	E std.	D × h × d	Dynamic C kN	Static C ₀ kN	M _p kN-m		M _y kN-m		M _R kN-m	Carriage kg	Rail kg/m
								Single	Double	Single	Double			
SME 15 SB SME 15 LSB	15	13	60	20	7.5×5.8×4.5	12.5 15.4	20.2 27.5	0.14 0.25	0.69 1.15	0.14 0.25	0.69 1.15	0.16 0.21	0.19 0.22	1.4
SME 20 SB SME 20 LSB	20	15.5	60	20	9.5×8.5×6	20.4 25.3	32.1 43.6	0.27 0.49	1.34 2.24	0.27 0.49	1.34 2.24	0.33 0.44	0.26 0.35	2.3
SME 25 SB SME 25 LSB	23	18	60	20	11×9×7	28.3 33.0	44.3 56.1	0.45 0.71	2.14 3.20	0.45 0.71	2.14 3.20	0.52 0.66	0.31 0.49	3.2
SME 25 SV SME 25 LSV	23	18	60	20	11×9×7	28.3 33.0	44.3 56.1	0.45 0.71	2.14 3.20	0.45 0.71	2.14 3.20	0.52 0.66	0.44 0.62	3.2
SME 30 SB SME 30 LSB	28	23	80	20	14×12×9	39.4 47.0	59.5 76.5	0.68 1.11	3.37 5.32	0.68 1.11	3.37 5.32	0.83 1.07	0.85 1.10	4.5
SME 35 SB SME 35 LSB	34	26	80	20	14×12×9	54.7 67.6	81.0 109.9	1.07 1.92	5.25 8.75	1.07 1.92	5.25 8.75	1.41 1.91	1.22 1.61	6.2
SME 45 SB SME 45 LSB	45	32	105	22.5	20×17×14	72.7 90.0	105.8 143.6	1.61 2.88	7.82 13.08	1.61 2.88	7.82 13.08	2.41 3.27	2.86 3.57	10.5