

---

## 12.2 Compact Type, MSB Series

### A. Construction

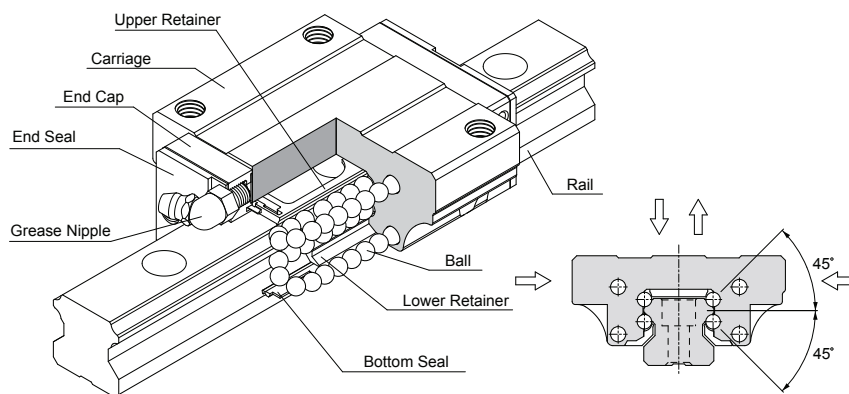

### B. Characteristics

The trains of balls are designed to a contact angle of 45° which enables it to bear an equal load in radial, reversed radial and lateral directions. Therefore, it can be applied in any installation direction. Furthermore, MSB series can achieve a well balanced preload for increasing rigidity in four directions while keeping a low frictional resistance. This is especially suit to high precision and high rigidity required motion.

The patent design of lubrication route makes the lubricant evenly distribute in each circulation loop. Therefore, the optimum lubrication can be achieved in any installation direction, and this promotes the performance in running accuracy, service life, and reliability.

### Compact, Four-way Equal Load

Compact design of the carriage with the four trains of balls are allocated to a circular contact angle at 45°, thus each train of balls can take up an equal rated load in all four directions. Moreover, a sufficient preload can be achieved to increase rigidity, and this makes it suitable for any kind of installation.

### Smooth Movement with Low Noise

The simplified design of circulating system with strengthened synthetic resin accessories makes the movement smooth and quiet.

### Self Alignment Capability

The self adjustment is performed spontaneously as the design of face-to-face (DF) circular arc groove. Therefore, the installation error could be compensated even under a preload, and which results in precise and smooth linear motion.

### Interchangeability

For interchangeable type of linear guideway, the dimensional tolerances are strictly maintained within a reasonable range, and this has made the random matching of the same size of rails and carriages possible. Therefore, the similar preload and accuracy can be obtained even under the random matching condition. As a result of this advantage, the linear guideway can be stocked as standard parts, the installation and maintenance become more convenient. Moreover, this is also beneficial for shortening the delivery time.

---

## C. Carriage Type

### Medium Load

#### MSB-TE Type

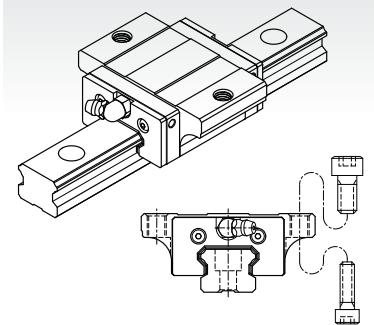

This type offers the installation either from top or bottom side of carriage.

#### MSB-TS Type

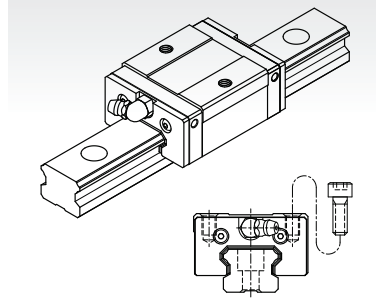

Square type with smaller width and can be installed from top side of carriage.

---

### Heavy Load

#### MSB-E Type

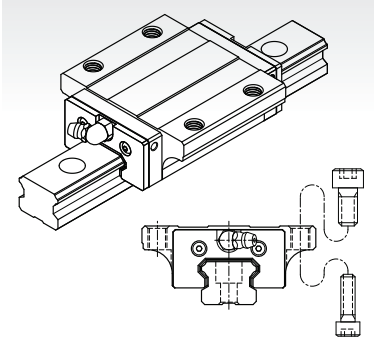

All dimensions are same as MSB-TE except the length is longer, which makes it more rigid.

#### MSB-S Type

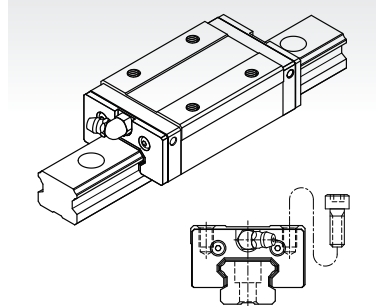

All dimensions are same as MSB-TS except the length is longer, which makes it more rigid.

**Ultra Heavy Load**

**MSB-LE Type**

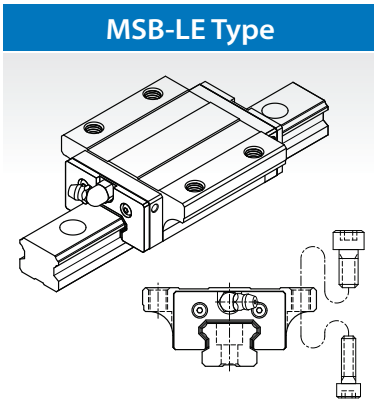

All dimensions are same as MSB-E except the length is longer, which makes it more rigid.

**MSB-LS Type**

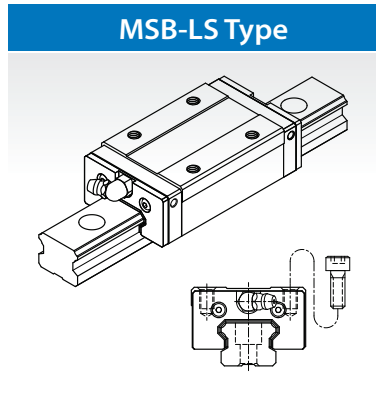

All dimensions are same as MSB-S except the length is longer, which makes it more rigid.

**D. Rail type**

**Counter bore (R, U type)**

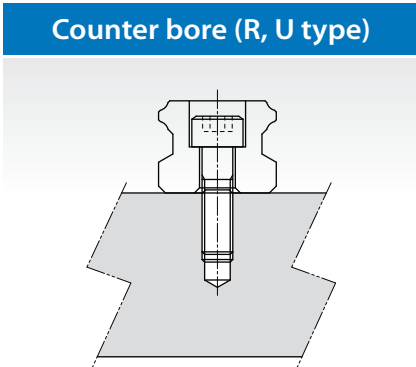

**Tapped Hole (T type)**

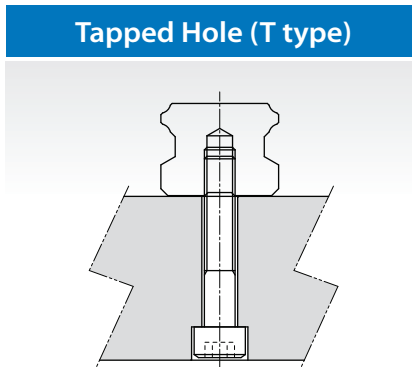

## E. Description of Specification

### (1) Non-Interchangeable Type

	MSB	25	E	2	SS	F0
Series : <b>MSB</b>						
Size : <b>15, 20, 25, 30, 35</b>						
Carriage type : (1) Medium load TE : Flange type, mounting either from top or bottom TS : Square type (2) Heavy load E : Flange type, mounting either from top or bottom S : Square type (3) Ultra heavy load LE : Flange type, mounting either from top or bottom LS : Square type						
Number of carriages per rail : <b>1, 2, 3 ...</b>						
Dust protection option of carriage : No symbol, <b>UU, SS, ZZ, DD, KK, LL, RR</b> (refer to chapter 15.1 Dust Proof)						
Preload : <b>FC</b> (Light preload), <b>F0</b> (Medium preload), <b>F1</b> (Heavy preload)						
Code of special carriage : <b>No symbol, A, B, C, D ...</b>						
Rail type : <b>R, U<sup>(1)</sup></b> (Counter-bore type), <b>T</b> (Tapped hole type)						
Rail length (mm)						
Rail hole pitch from start side ( <b>E1</b> , see Fig.12.2)						
Rail hole pitch to the end side ( <b>E2</b> , see Fig.12.2)						
Accuracy grade : <b>N, H, P, SP, UP</b>						
Code of special rail : <b>No symbol, A, B ...</b>						
Dust protection option of rail : <b>No symbol, /CC, /MC, /MD</b> (refer to chapter 15.1 Code of contamination fro Rail)						
Number of rails per axis : <b>No symbol, II, III, IV ...</b>						

Notr<sup>(1)</sup> : U type rail is only applicable for MSB15 with M4 mounting hole.

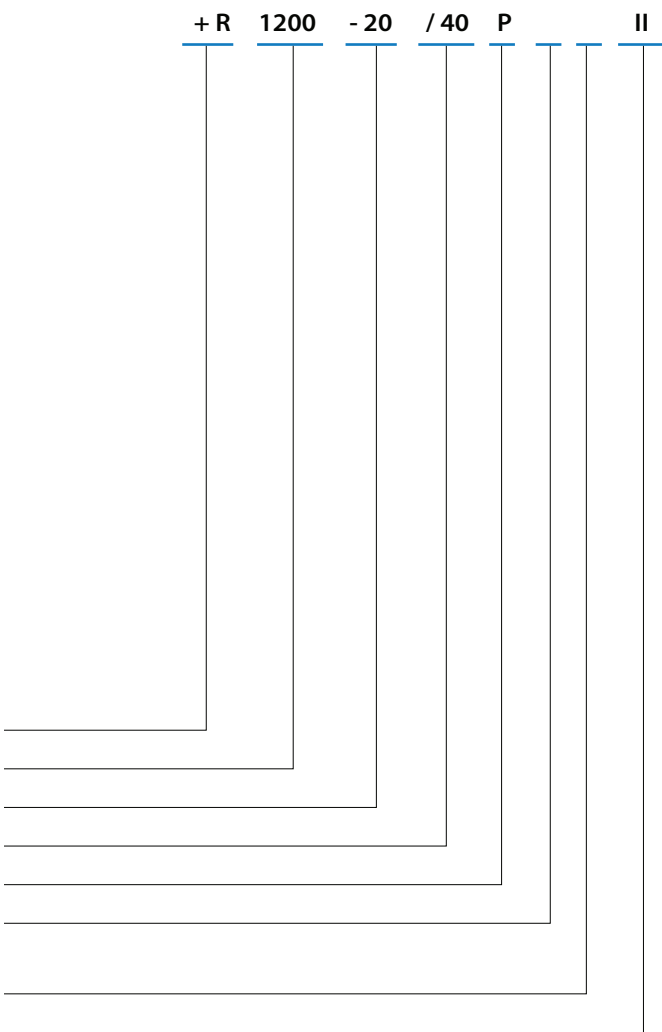

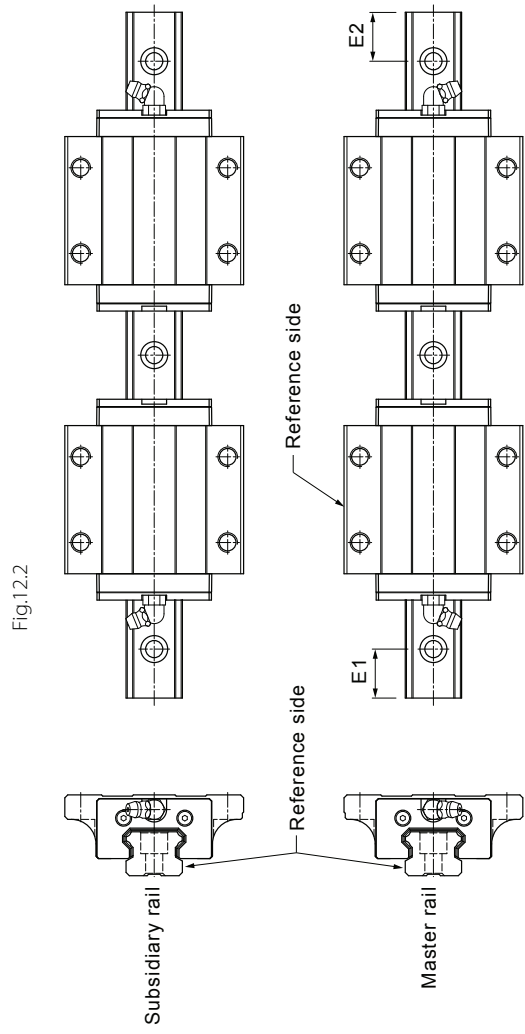
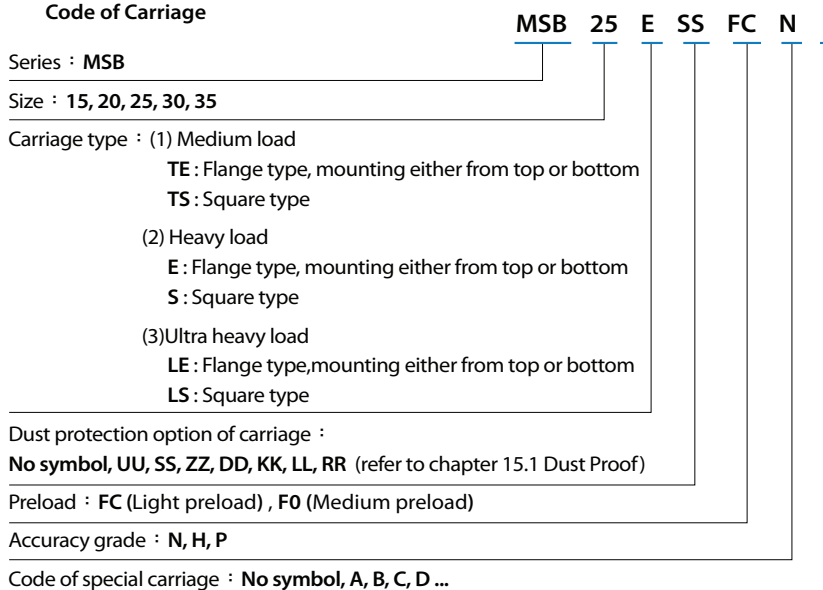

Fig.12.2

## (2) Interchangeable Type

### Code of Carriage



### Code of Rail

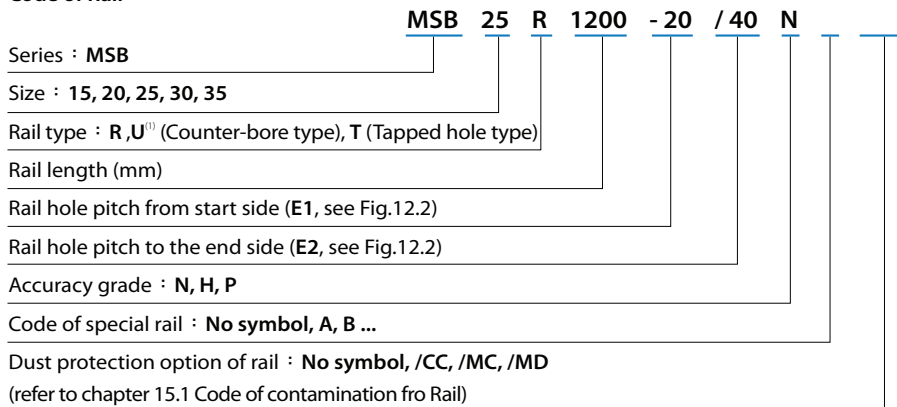

Notr<sup>(1)</sup> : U type rail is only applicable for MSB15 with M4 mounting hole.



## F. Accuracy Grade

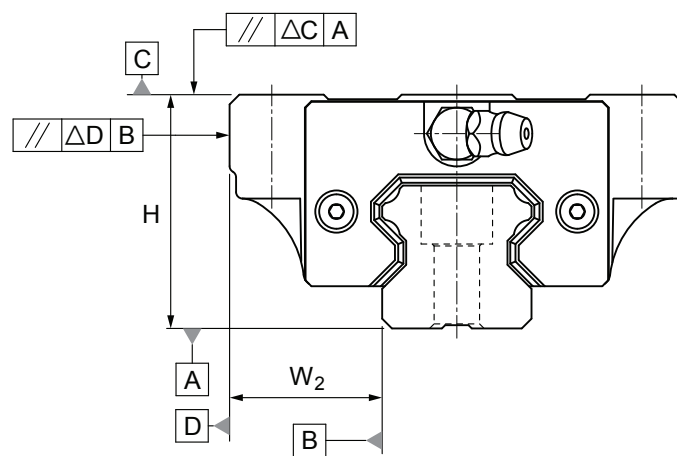

Table 1 Running Parallelism

Rail length (mm)		Running Parallelism Values( $\mu\text{m}$ )				
Above	Or less	N	H	P	SP	UP
0	315	9	6	3	2	1.5
315	400	11	8	4	2	1.5
400	500	13	9	5	2	1.5
500	630	16	11	6	2.5	1.5
630	800	18	12	7	3	2
800	1000	20	14	8	4	2
1000	1250	22	16	10	5	2.5
1250	1600	25	18	11	6	3
1600	2000	28	20	13	7	3.5
2000	2500	30	22	15	8	4
2500	3000	32	24	16	9	4.5
3000	3500	33	25	17	11	5
3500	4000	34	26	18	12	6

## A Non-Interchangeable Type

Model No.	Item	Accuracy Grade				
		Normal N	High H	Precision P	Super Precision SP	Ultra Precision UP
15 20	Tolerance for height H	±0.1	±0.03	0 -0.03	0 -0.015	0 -0.008
	Height difference $\Delta H$	0.02	0.01	0.006	0.004	0.003
	Tolerance for distance $W_2$	±0.1	±0.03	0 -0.03	0 -0.015	0 -0.008
	Difference in distance $W_2(\Delta W_2)$	0.02	0.01	0.006	0.004	0.003
	Running parallelism of surface C with surface A	$\Delta C$ (see the table 1)				
	Running parallelism of surface D with surface B	$\Delta D$ (see the table 1)				
25 30 35	Tolerance for height H	±0.1	±0.04	0 -0.04	0 -0.02	0 -0.01
	Height difference $\Delta H$	0.02	0.015	0.007	0.005	0.003
	Tolerance for distance $W_2$	±0.1	±0.04	0 -0.04	0 -0.02	0 -0.01
	Difference in distance $W_2(\Delta W_2)$	0.03	0.015	0.007	0.005	0.003
	Running parallelism of surface C with surface A	$\Delta C$ (see the table 1)				
	Running parallelism of surface D with surface B	$\Delta D$ (see the table 1)				

## B Interchangeable Type

Model No.	Item	Accuracy Grade		
		Normal N	High H	Precision P
15 20	Tolerance for height H	±0.1	±0.03	$\begin{matrix} 0 \\ -0.03 \end{matrix}$
	Height difference $\Delta H$	0.02	0.01	0.006
	Tolerance for distance $W_2$	±0.1	±0.03	$\begin{matrix} 0 \\ -0.03 \end{matrix}$
	Difference in distance $W_2(\Delta W_2)$	0.02	0.01	0.006
	Running parallelism of surface C with surface A	$\Delta C$ (see the table 1)		
	Running parallelism of surface D with surface B	$\Delta D$ (see the table 1)		
25 30 35	Tolerance for height H	±0.1	±0.04	$\begin{matrix} 0 \\ -0.04 \end{matrix}$
	Height difference $\Delta H$	0.02	0.015	0.007
	Tolerance for distance $W_2$	±0.1	±0.04	$\begin{matrix} 0 \\ -0.04 \end{matrix}$
	Difference in distance $W_2(\Delta W_2)$	0.03	0.015	0.007
	Running parallelism of surface C with surface A	$\Delta C$ (see the table 1)		
	Running parallelism of surface D with surface B	$\Delta D$ (see the table 1)		

### G. Preload Grade

Series	Preload grade		
	Light preload (FC)	Medium preload (F0)	Heavy preload (F1)
MSB15T	0~0.02C	0.03~0.05C	-
MSB20T			
MSB25T			0.05~0.08C
MSB30T			
MSB15	0~0.02C	0.03~0.05C	0.05~0.08C
MSB20			
MSB25			
MSB30			
MSB35			
MSB35L			

Note: C is basic dynamic load rating in above table. Refer to the specification of products, please.

### H. The Shoulder Height and Corner Radius for Installation

#### MSB series

Unit: mm

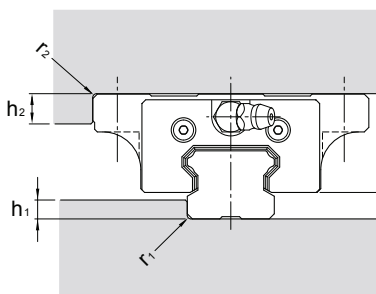

Model No.	$r_1$ (max.)	$r_2$ (max.)	$h_1$	$h_2$	$H_2$
15	0.5	0.5	3	4	4.5
20	0.5	0.5	4	5	6
25	1	1	5	5	7
30	1	1	7	5	9.5
35	1	1	8	6	9.5

---

## I. Dimensional Tolerance of Mounting Surface

### MSB Series

With the self alignment capability, the minor dimensional error in mounting surface could be compensated and achieves smooth linear motion. The tolerances of parallelism between two axes are shown as below.

#### The parallel deviation between two axes ( $e_1$ )

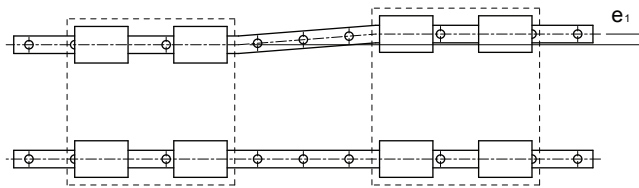

Unit:  $\mu m$

Model No.	Preload Grade		
	FC	F0	F1
15	25	18	-
20	25	20	18
25	30	22	20
30	40	30	27
35	50	35	30

Level difference between two axes ( $e_2$ )

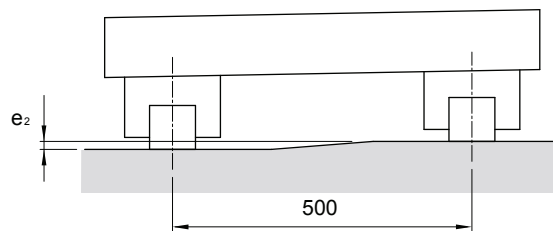

Unit:  $\mu m$

Model No.	Preload Grade		
	FC	F0	F1
15	130	85	-
20	130	85	50
25	130	85	70
30	170	110	90
35	210	150	120

Note: The permissible values in table are applicable when the span is 500mm wide.

## J. Rail Maximum Length and Standrad

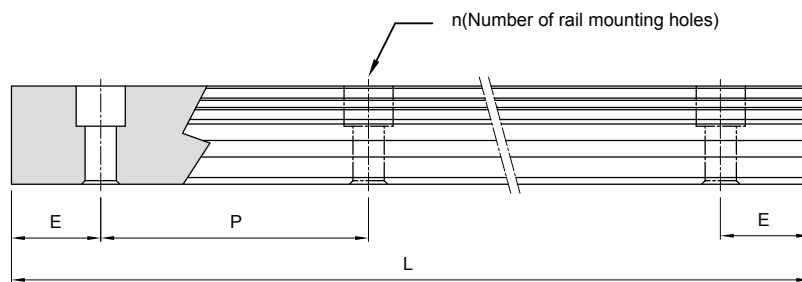

$$L = (n-1) \times P + 2 \times E$$

*L*: Total Length of rail (mm)

*n*: Nuber of mounting holes

*P*: Distance between any two holes (mm)

*E*: Distance from the center of the last hole to the edge (mm)

Unit: mm

Model No.	Standard Pitch (P)	Standard (E <sub>std.</sub> )	Minimum (E <sub>min.</sub> )	Max (L <sub>0</sub> max.)
MSB 15	60	20	5	4000
MSB 20	60	20	6	4000
MSB 25	60	20	7	4000
MSB 30	80	20	7	4000
MSB 35	80	20	8	4000

## K. Tapped-hole Rail Dimensions

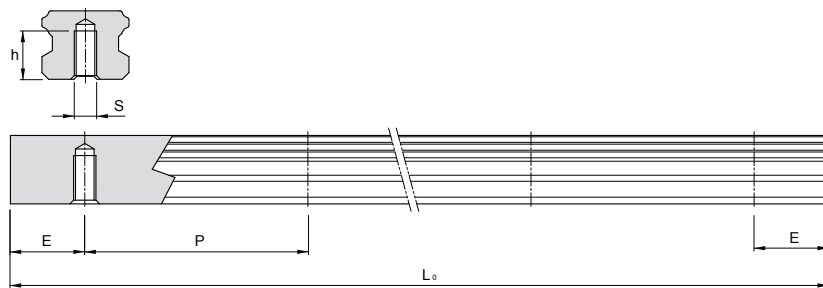

Rail Model	S	h(mm)
MSB 15 T	M5	7
MSB 20 T	M6	9
MSB 25 T	M6	10
MSB 30 T	M8	14
MSB 35 T	M8	16



## Dimensions of MSB-TE / MSB-E

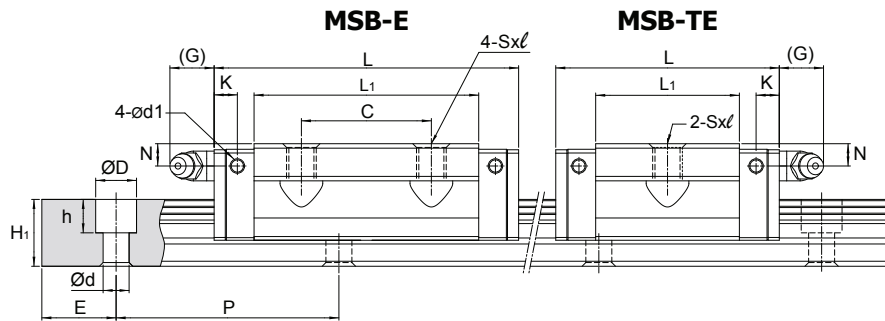

Unit: mm

Model No.	External dimension				Carriage dimension										Grease Nipple	
	Height H	Width W	Length L	W <sub>2</sub>	H <sub>2</sub>	B	C	S × ℓ	L <sub>1</sub>	T	T <sub>1</sub>	N	G	K		d <sub>1</sub>
MSB 15 TE MSB 15 E	24	52	40 57	18.5	4.5	41	- 26	M5×7	23.5 40.5	5	7	5.5	5.5	5.1	3.3	G-M4
MSB 20 TE MSB 20 E	28	59	48 67	19.5	6	49	- 32	M6×9	29 48	5	9	5.5	12	5.9	3.3	G-M6
MSB 25 TE MSB 25 E	33	73	60.2 82	25	7	60	- 35	M8×10	38.7 60.5	7	10	6	12	6.3	3.3	G-M6
MSB 30 TE MSB 30 E	42	90	68 96.7	31	9.5	72	- 40	M10×10	43.3 72	7	10	8	12	6.3	3.3	G-M6
MSB 35 TE MSB 35 E MSB 35 LE	48	100	78 112 137.5	33	9.5	82	- 50 72	M10×13	46 80 105.5	9	13	8.5	12	9.8	3.3	G-M6

Note: Rail mounting holes for M3 (6x4.5x3.5) and M4 (7.5x5.3x4.5) are available for MSB15 rail. The codes of rail type are MSB15R for M3 mounting holes, and MSB15U for M4 mounting holes.

Note: The basic dynamic load rating C of ball type is based on the 50 km for nominal life. The conversion between C for 50 km and C<sub>100</sub> for 100 km is C=1.26 × C<sub>100</sub>.

Note\*: Single: Single carriage/ Double: Double carriages closely contacting with each other.

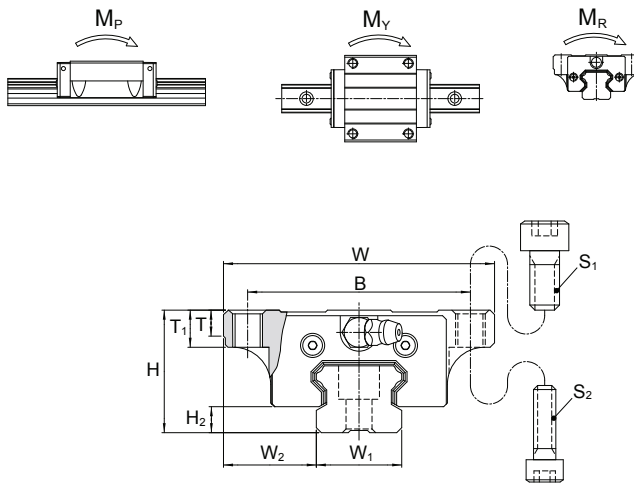

Model No.	Bolt Size	
	S <sub>1</sub>	S <sub>2</sub>
MSB 15	M5	M4
MSB 20	M6	M5
MSB 25	M8	M6
MSB 30	M10	M8
MSB 35	M10	M8

Unit: mm

Model No.	Rail dimension					Basic load rating		Static moment rating				Weight		
	Width W <sub>i</sub>	Height H <sub>i</sub>	Pitch P	E std.	D × h × d	Dynamic C kN	Static C <sub>0</sub> kN	M <sub>p</sub> kN-m		M <sub>y</sub> kN-m		M <sub>R</sub> kN-m	Carriage kg	Rail kg/m
								Single <sup>+</sup>	Double <sup>+</sup>	Single <sup>+</sup>	Double <sup>+</sup>			
MSB 15 TE MSB 15 E	15	12.5	60	20	6×4.5×3.5 (7.5×5.3×4.5)	6.7 10.0	9.6 16.9	0.04 0.10	0.26 0.61	0.04 0.10	0.26 0.61	0.07 0.13	0.12 0.21	1.2
MSB 20 TE MSB 20 E	20	15	60	20	9.5×8.5×6	9.7 13.9	14.2 23.6	0.07 0.18	0.44 0.97	0.07 0.18	0.44 0.97	0.14 0.24	0.20 0.34	2
MSB 25 TE MSB 25 E	23	18	60	20	11×9×7	15.6 22.3	22.1 36.9	0.13 0.35	0.91 1.87	0.13 0.35	0.91 1.87	0.26 0.43	0.39 0.60	3
MSB 30 TE MSB 30 E	28	23	80	20	11×9×7	23.1 32.9	31.8 53.1	0.23 0.60	1.39 3.15	0.23 0.60	1.39 3.15	0.45 0.74	0.65 1.08	4.4
MSB 35 TE MSB 35 E MSB 35 LE	34	27.5	80	20	14×12×9	35.7 52.0 63.6	44.0 75.5 100.6	0.34 0.93 1.60	2.81 5.47 8.67	0.34 0.93 1.60	2.81 5.47 8.67	0.75 1.28 1.67	0.91 1.61 1.80	6.2 1.61 6.6

## Dimensions of MSB-TS / MSB-S

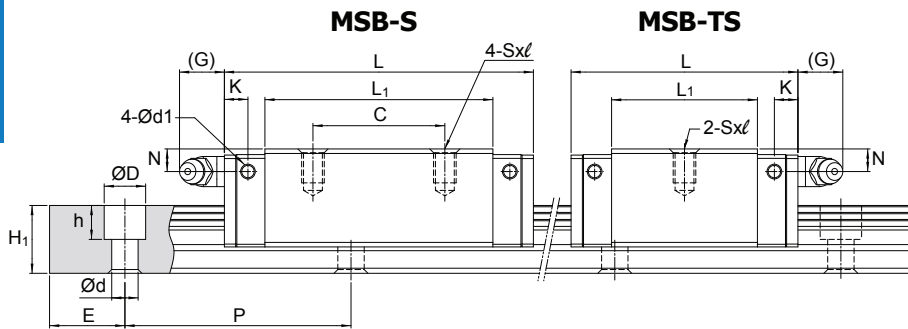

Unit: mm

Model No.	External dimension							Carriage dimension								Grease Nipple
	Height H	Width W	Length L	W <sub>2</sub>	H <sub>2</sub>	B	C	S × ℓ	L <sub>1</sub>	T	N	G	K	d <sub>1</sub>		
MSB 15 TS MSB 15 S	24	34	40 57	9.5	4.5	26	- 26	M4×6	23.5 40.5	6	5.5	5.5	5.1	3.3	G-M4	
MSB 20 TS MSB 20 S	28	42	48 67	11	6	32	- 32	M5×7	29 48	6	5.5	12	5.9	3.3	G-M6	
MSB 25 TS MSB 25 S	33	48	60.2 82	12.5	7	35	- 35	M6×9	38.7 60.5	8	6	12	6.3	3.3	G-M6	
MSB 30 TS MSB 30 S	42	60	68 96.7	16	9.5	40	- 40	M8×12	43.3 72	8	8	12	6.3	3.3	G-M6	
MSB 35 TS MSB 35 S MSB 35 LS	48	70	78 112 137.5	18	9.5	50	- 50 72	M8×12	46 80 105.5	12.5	8.5	11.5	9.8	3.3	G-M6	

Note: Rail mounting holes for M3 (6x4.5x3.5) and M4 (7.5x5.3x4.5) are available for MSB15 rail. The codes of rail type are MSB15R for M3 mounting holes, and MSB15U for M4 mounting holes.

Note: The basic dynamic load rating C of ball type is based on the 50 km for nominal life. The conversion between C for 50 km and C<sub>100</sub> for 100 km is C=1.26 × C<sub>100</sub>.

Note \*: Single: Single carriage/ Double: Double carriages closely contacting with each other.

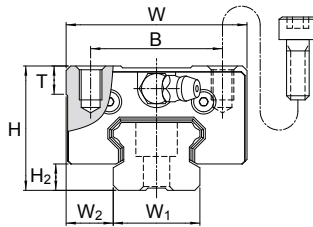
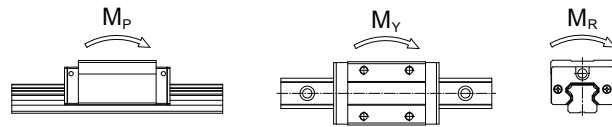

Unit: mm

Model No.	Rail dimension					Basic load rating		Static moment rating					Weight	
	Width $W_1$	Height $H_1$	Pitch $P$	E std.	D × h × d	Dynamic $C$ kN	Static $C_0$ kN	$M_p$ kN-m		$M_y$ kN-m		$M_R$ kN-m	Carriage kg	Rail kg/m
								Single*	Double*	Single*	Double*			
MSB 15 TS MSB 15 S	15	12.5	60	20	6×4.5×3.5 (7.5×5.3×4.5)	6.7 10.0	9.6 16.9	0.04 0.10	0.26 0.61	0.04 0.10	0.26 0.61	0.07 0.13	0.09 0.16	1.2
MSB 20 TS MSB 20 S	20	15	60	20	9.5×8.5×6	9.7 13.9	14.2 23.6	0.07 0.18	0.44 0.97	0.07 0.18	0.44 0.97	0.14 0.24	0.16 0.26	2
MSB 25 TS MSB 25 S	23	18	60	20	11×9×7	15.6 22.3	22.1 36.9	0.13 0.35	0.91 1.87	0.13 0.35	0.91 1.87	0.26 0.43	0.29 0.45	3
MSB 30 TS MSB 30 S	28	23	80	20	11×9×7	23.1 32.9	31.8 53.1	0.23 0.60	1.39 3.15	0.23 0.60	1.39 3.15	0.45 0.74	0.52 0.82	4.4
MSB 35 TS MSB 35 S MSB 35 LS	34	27.5	80	20	14×12×9	35.7 52.0 63.6	44.0 75.5 100.6	0.34 0.93 1.60	2.81 5.47 8.67	0.34 0.93 1.60	2.81 5.47 8.67	0.75 1.28 1.67	0.81 1.13 1.49	6.2